

POWERMILL™ CLIMBER

PARTS MANUAL

95PS-ALLXX-XX01, 95PS-ALLXX-XX02,

95PS-ALLXX-XX01PF, 95PS-ALLXX-XX02PF



Table of Contents

Miscellaneous Part Numbers	1
Front Shrouds	2
Side Panels	4
Stepping System	5
Handlebar Assemblies	8
Console Supports	11
Drive System	12
Base Electronics	17
Wiring Diagrams	22
Parts List	22
Base	23
Console - Integrity	24
Console - Discover	25
Console - Explore	26
Consoles	27
Discover SE, Discover SI & Explore	27
Integrity	28

Miscellaneous Part Numbers

Item	Alpha Code	Part Number	Description (Quantity)
MISC-001	PMA, PFB, PMD, PFD	9281100	CABLE TIE GROMMETS (20)
MISC-002	PMA, PFB, PMD, PFD	9251000	POWER CORD BRACKET
MISC-003	PMA, PFB, PMD, PFD	9284000	POWER CORD ADHESIVE PAD
MISC-004	PMA, PMD	0017-00008-0204	ARCTIC SILVER TOUCH UP PAINT: SPRAY CAN
MISC-005	PMA, PMD	0017-00008-0231	CHARCOAL GRAY TOUCH UP PAINT: SPRAY CAN
MISC-006	PMA, PMD	0017-00008-0223	PEARL WHITE BASE TOUCH UP PAINT: SPRAY CAN
MISC-007	PMA, PMD	0017-00008-0224	PEARL WHITE TOP TOUCH UP PAINT: SPRAY CAN
MISC-008	PMA, PMD	0017-00008-0227	TITANIUM TOUCH UP PAINT: SPRAY CAN
MISC-009	PMA, PMD	0017-00008-0229	METALLIC BLACK TOUCH UP PAINT: SPRAY CAN
MISC-010	PMA, PMD	0017-00008-0205	ARCTIC SILVER TOUCH UP PAINT: 0.5 OZ BOTTLE W/ APPLICATOR
MISC-011	PMA, PMD	0017-00008-0228	TITANIUM TOUCH UP PAINT: 0.5 OZ BOTTLE W/ APPLICATOR
MISC-012	PMA, PMD	0017-00008-0230	METALLIC BLACK TOUCH UP PAINT: 0.5 OZ BOTTLE W/ APPLICATOR
MISC-013	PMA, PMD	0017-00008-0232	CHARCOAL GRAY TOUCH UP PAINT: 0.5 OZ BOTTLE W/ APPLICATOR
MISC-014	PMA, PMD	0017-00008-0226	PEARL WHITE TOP TOUCH UP PAINT:0.5 OZ BOTTLE W/ APPLICATOR
MISC-015	PMA, PMD	0017-00008-0225	PEARL WHITE BASE TOUCH UP PAINT: 0.5 OZ BOTTLE W/ APPLICATOR
MISC-016	PMA, PMD	0017-00008-0206	ARCTIC SILVER TOUCH UP PAINT: 0.33 OZ PEN
MISC-017	PMA, PFB, PMD, PFD	0017-00003-1084	LINE CORD POWERMILL ARGENTINA HIGH VOLTAGE
MISC-018	PMA, PFB, PMD, PFD	0017-00003-1085	LINE CORD POWERMILL AUSTRALIA HIGH VOLTAGE
MISC-019	PMA, PFB, PMD, PFD	0017-00003-1083	LINE CORD POWERMILL BRAZIL HIGH VOLTAGE
MISC-020	PMA, PFB, PMD, PFD	0017-00003-1088	LINE CORD POWERMILL CHINA HIGH VOLTAGE
MISC-021	PMA, PFB, PMD, PFD	0017-00003-1086	LINE CORD POWERMILL CONT EUROPE HIGH VOLTAGE
MISC-022	PMA, PFB, PMD, PFD	0017-00003-1082	LINE CORD POWERMILL DOM LOW VOLT
MISC-023	PMA, PFB, PMD, PFD	0017-00003-1087	LINE CORD POWERMILL UK HIGH VOLTAGE
MISC-024	PMA, PFB, PMD, PFD	9273600	STAR WASHER (2)
MISC-025	PMA, PFB, PMD, PFD	1005544-0001	LINE CORD POWERMILL DOM LOW VOLT STRAIGHT PLUG "OPTION SERVICE PART ONLY"

Front Shrouds

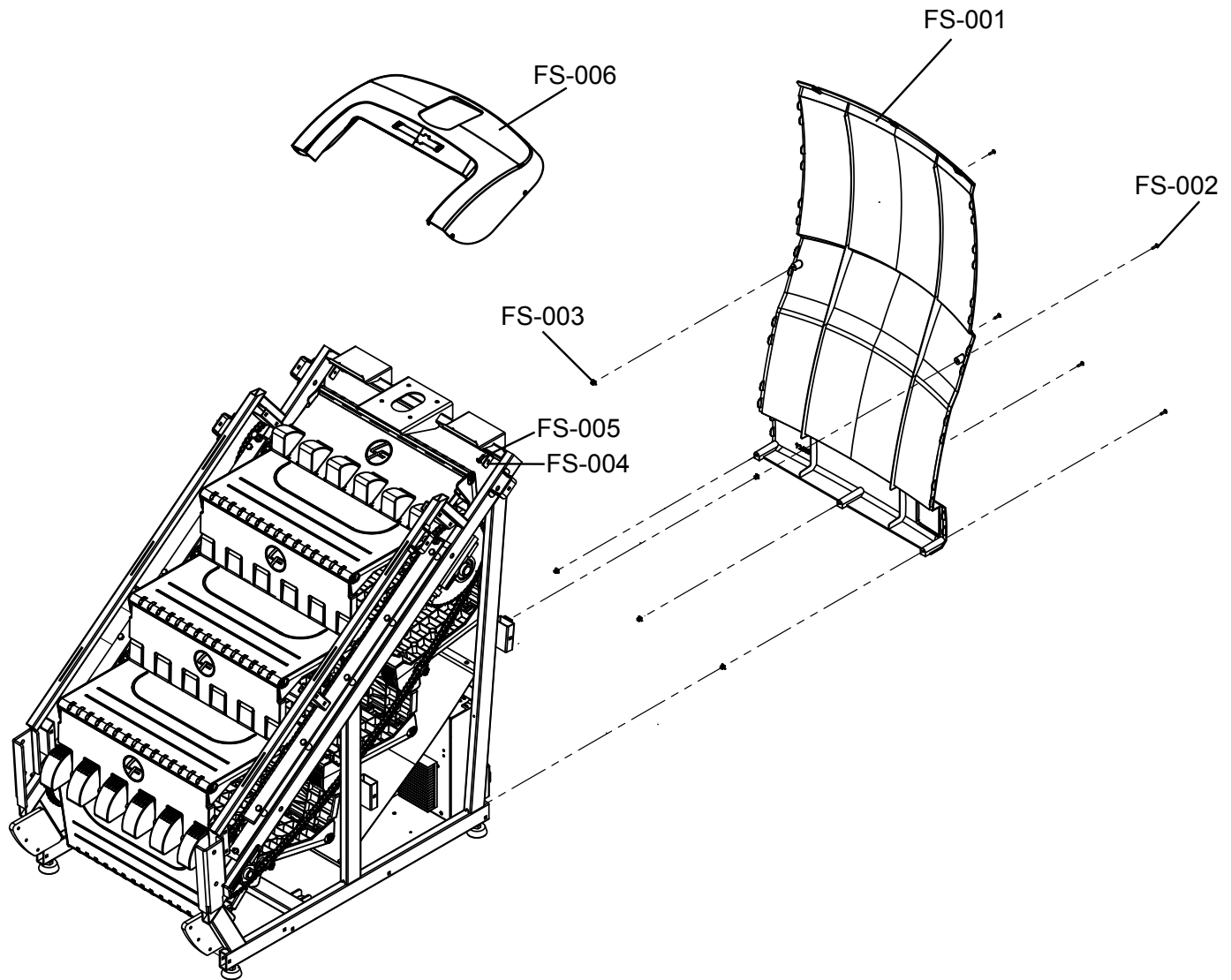

Parts List

Item	Alpha Code	Part Number	Description (Quantity)
FS-001	PMA, PMD	9280300	FRONT SHROUD
	PFB, PFD	9286600	FRONT SHROUD (PLANET FITNESS)
FS-002	PMA, PFB, PMD, PFD	9276700	SHROUD SCREW (30)
FS-003	PMA, PFB PMD, PFD	0017-00042-1055	GROMMET (30)
FS-004	PMA, PFB PMD, PFD	9283900	INNER SHROUD FRONT BRACKET (2)
FS-005	PMA, PFB PMD, PFD	0017-00101-2068	SCREW (2)
FS-006	PMA, PMD	9285900	TOP SHROUD
	PFB, PFD	9286400	TOP SHROUD (PLANET FITNESS)

Front Shrouds

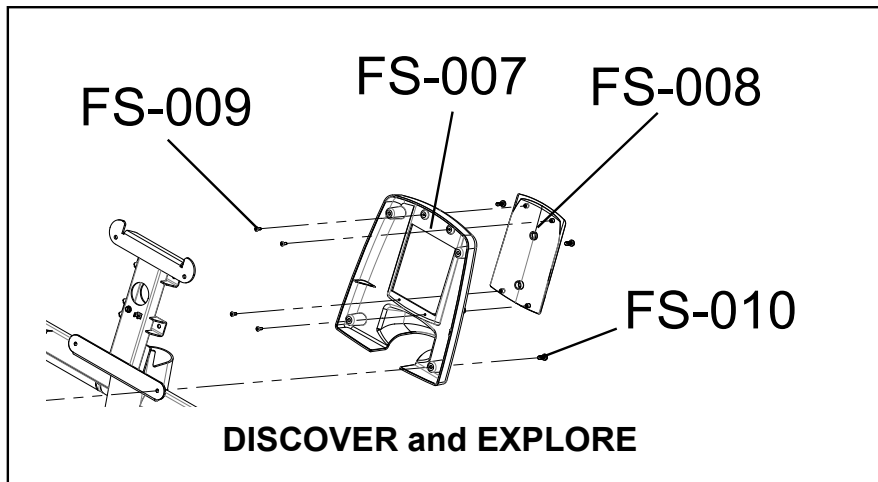
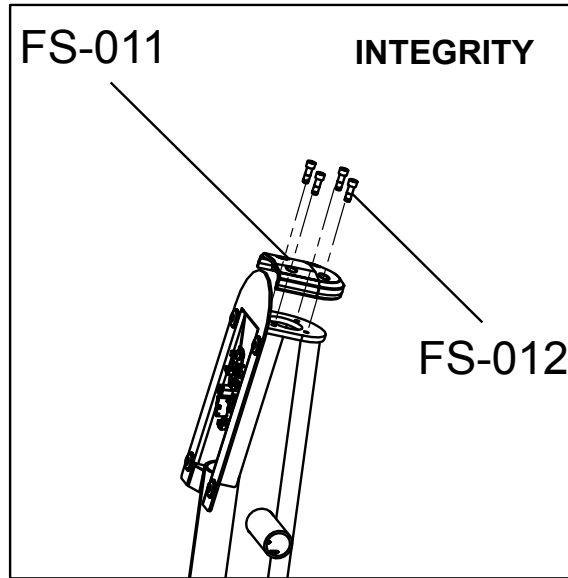

Parts List

Item	Alpha Code	Part Number	Description (Quantity)
FS-007	PMA, PMD	1017292-0001	COVER; CONSOLE JUNCTION DISCOVER
FS-008	PMA, PMD	AK92-00059-2400	MIDDLE SHROUD CONSOLE; CHGR
FS-009	PMA, PMD	0017-00101-1275	JUNCTION SCREW (4)
FS-010	PMA, PMD	0017-00101-1940	DISCOVER CONSOLE MOUNTING SCREW (4)
FS-011	PMA, PFB, PMD, PFD	9276601	INTEGRITY UPRIGHT CAP
FS-012	PMA, PFB PMD, PFD	0017-00101-1702	UPRIGHT CAP SCREW (4)

Side Panels

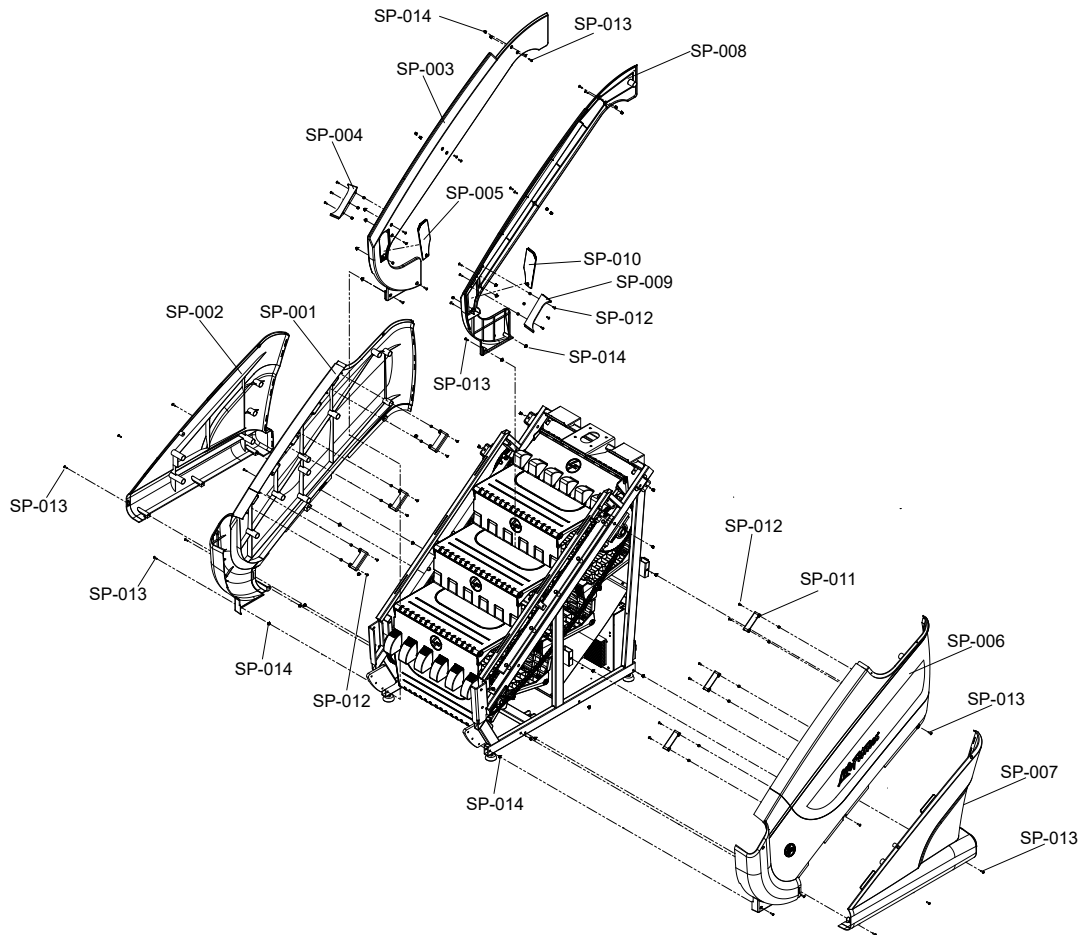

Parts List

Item	Alpha Code	Part Number	Description (Quantity)
SP-001	PMA, PMD	9268700	UPPER LEFT PANEL
	PFB, PFD	9286100	UPPER LEFT PANEL (PLANET FITNESS)
SP-002	PMA, PMD	9267900	LOWER LEFT PANEL
	PFB, PFD	9286300	LOWER LEFT PANEL (PLANET FITNESS)
SP-003	PMA, PFB, PMD, PFD	9269300	INNER LEFT PANEL
SP-004	PMA, PFB, PMD, PFD	9268400	LEFT REAR INSERT SHROUD
SP-005	PMA, PFB, PMD, PFD	9269500	LEFT ACCESS PANEL
SP-006	PMA, PMD	9268600	UPPER RIGHT PANEL
	PFB, PFD	9286000	UPPER RIGHT PANEL (PLANET FITNESS)
SP-007	PMA, PMD	9267700	LOWER RIGHT PANEL
	PFB, PFD	9286200	LOWER RIGHT PANEL (PLANET FITNESS)
SP-008	PMA, PFB, PFB, PFD	9269200	INNER RIGHT PANEL
SP-009	PMA, PFB, PFB, PFD	9268300	RIGHT REAR INSERT SHROUD
SP-010	PMA, PFB, PFB, PFD	9269400	RIGHT ACCESS PANEL
SP-011	PMA, PFB, PFB, PFD	9271400	SIDE SHROUD MOUNTING TAB (6)
SP-012	PMA, PFB, PFB, PFD	0017-00101-2068	INSERT/ACCESS PANEL SCREW (22)
SP-013	PMA, PFB, PFB, PFD	9276700	PANEL SCREW (48)
SP-014	PMA, PFB, PFB, PFD	0017-00042-1055	GROMMET (48)

Stepping System

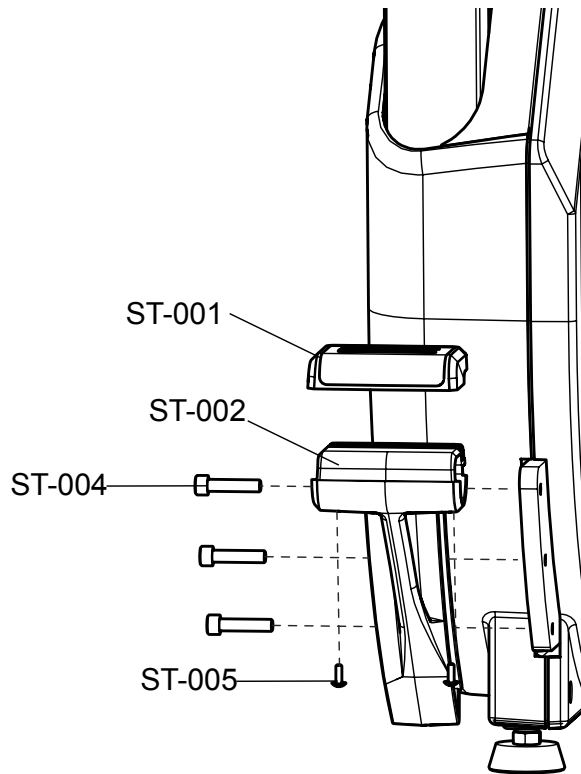

Parts List

Item	Alpha Code	Part Number	Description (Quantity)
ST-001	PMA, PFB, PMD, PFD	9278500	STEP ASSIST CAP (2)
ST-002	PMA, PFB, PMD, PFD	9278300	LEFT STEP ASSIST CASTING
ST-003	PMA, PFB, PMD, PFD	9278200	RIGHT STEP ASSIST CASTING (<i>not shown</i>)
ST-004	PMA, PFB, PMD, PFD	9273300	STEP ASSIST MOUNTING BOLT (6)
ST-005	PMA, PFB, PMD, PFD	0017-00101-2068	STEP ASSIST CAP SCREW (4)

Stepping System

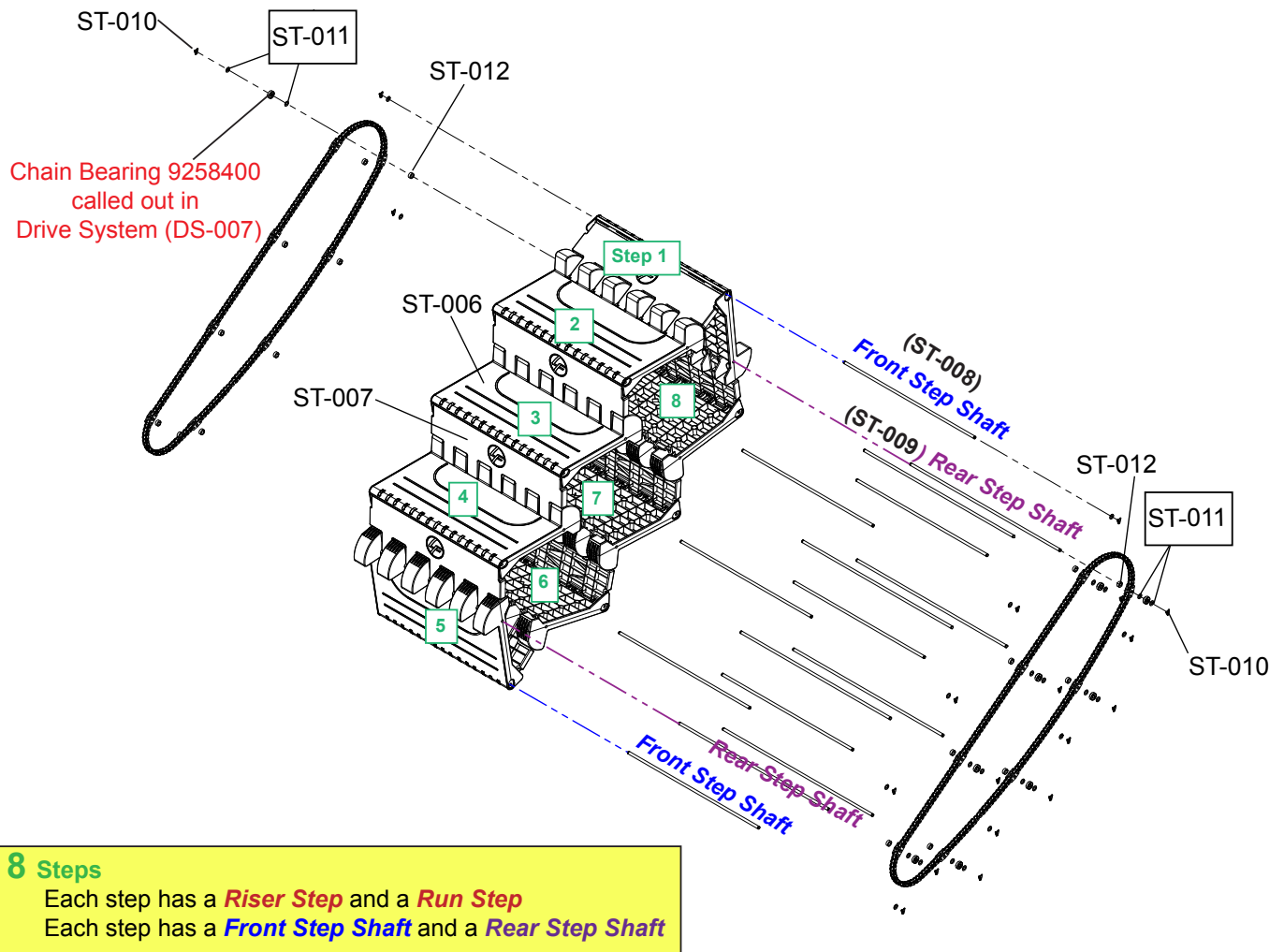

Parts List

Item	Alpha Code	Part Number	Description (Quantity)
ST-006 *	PMA, PFB, PMD, PFD	9257700	RUN STEP (8)
ST-007 *	PMA, PFB, PMD, PFD	9257800	RISER STEP (8)
ST-008	PMA, PFB, PMD, PFD	9587300	FRONT STEP SHAFT (8)
ST-009	PMA, PFB, PMD, PFD	9587400	REAR STEP SHAFT (8)
ST-010	PMA, PFB, PMD, PFD	9258000	CRIMPED RETAINING RING (32)
ST-011	PMA, PFB, PMD, PFD	9258100	SHAFT WASHER (48)
ST-012	PMA, PFB, PMD, PFD	9258300	SPACER (16)

* When replacing a step it may be necessary to order replacement front and rear step shafts.

Stepping System

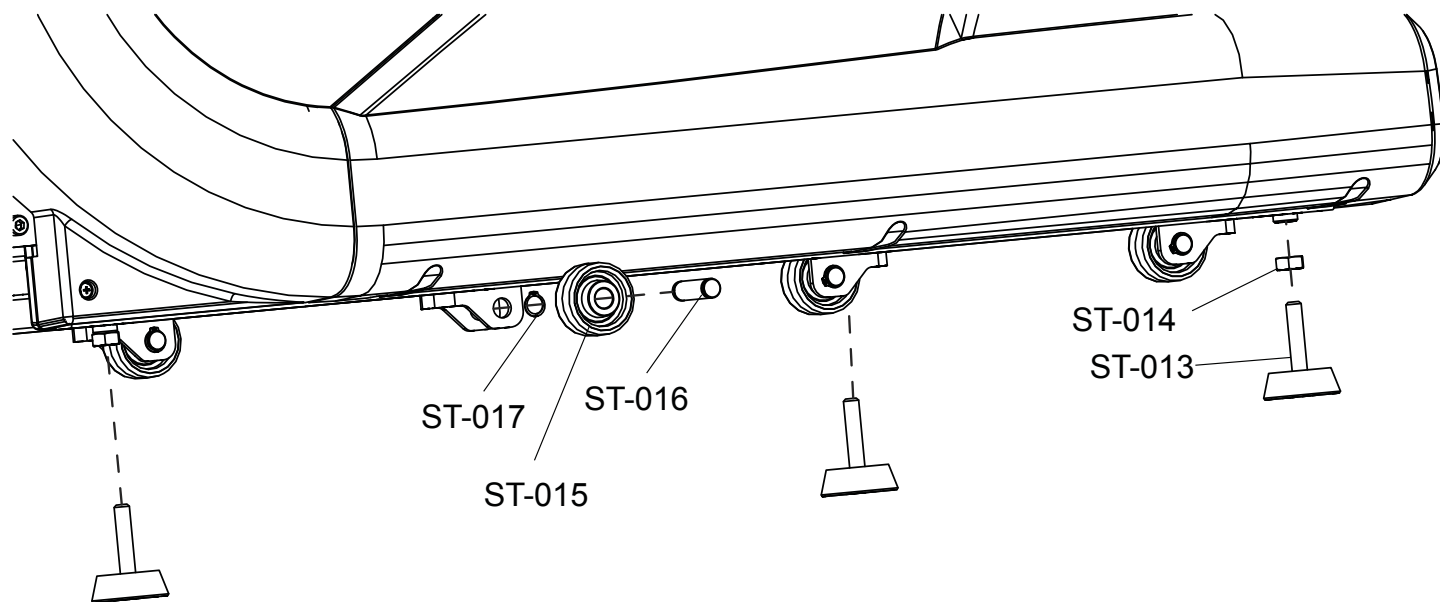

Parts List

Item	Alpha Code	Part Number	Description (Quantity)
ST-013	PMA, PFB, PMD, PFD	0K76-01086-0000	LEVELERS (4)
ST-014	PMA, PFB, PMD, PFD	0017-00103-0384	NUT (4)
ST-015	PMA, PFB, PMD, PFD	REX2AX2	ROLLER WHEELS (4)
ST-016	PMA, PFB, PMD, PFD	9257000	PIN (4)
ST-017	PMA, PFB, PMD, PFD	9282000	RETAINING RING (8)

Handlebar Assemblies

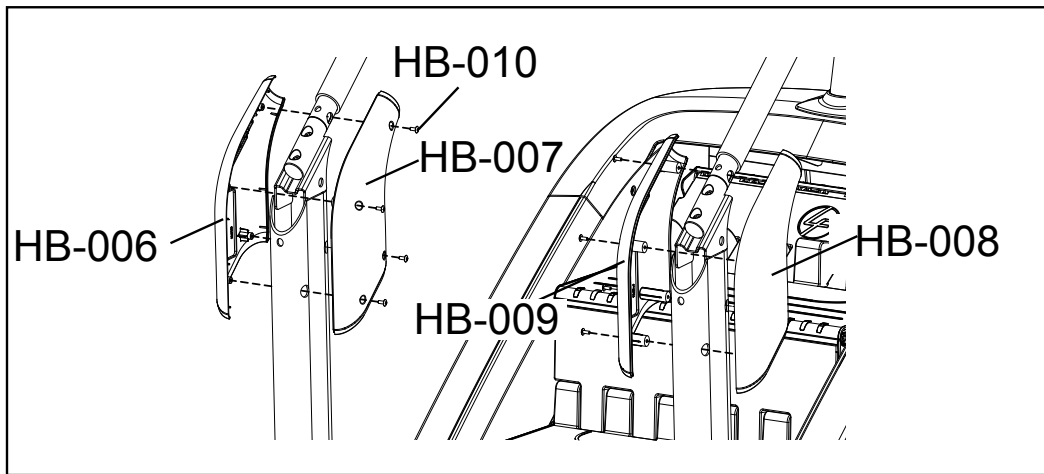
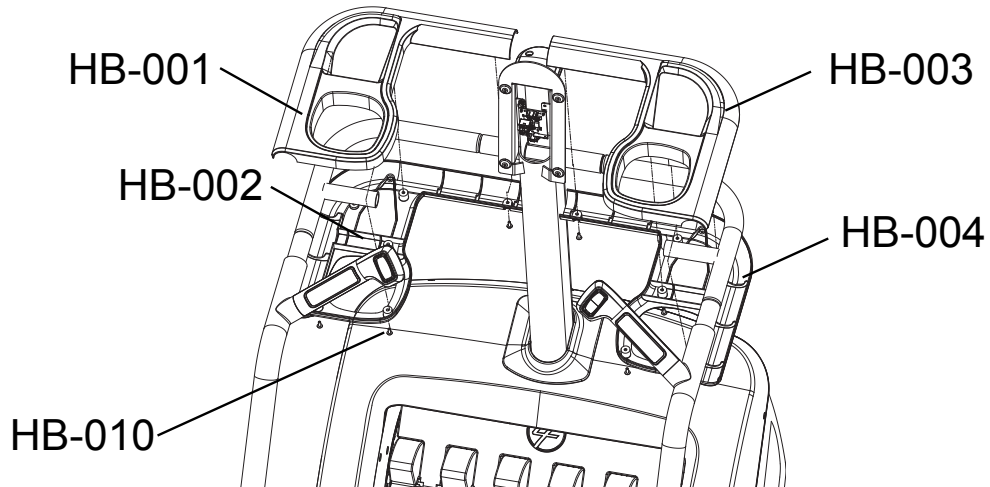
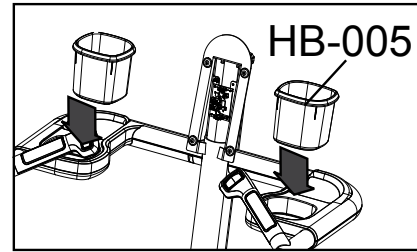

Parts List

Item	Alpha Code	Part Number	Description (Quantity)
HB-001	PMA, PFB, PMD, PFD	9277800	LEFT TOP ACCESSORY TRAY
HB-002	PMA, PFB, PMD, PFD	9585200	LEFT ACCESSORY TRAY BOTTOM
HB-003	PMA, PFB, PMD, PFD	9277900	RIGHT TOP ACCESSORY TRAY
HB-004	PMA, PFB, PMD, PFD	9585300	RIGHT ACCESSORY TRAY BOTTOM
HB-005	PMA, PFB, PMD, PFD	0K67-01055-2400	CUP HOLDER (2)
HB-006	PMA, PFB, PMD, PFD	9276900	LEFT OUTER HANDLEBAR COVER
HB-007	PMA, PFB, PMD, PFD	9269100	LEFT INNER HANDLE BAR COVER
HB-008	PMA, PFB, PMD, PFD	9276800	RIGHT OUTER HANDLEBAR COVER
HB-009	PMA, PFB, PMD, PFD	9268900	RIGHT INNER HANDLE BAR COVER
HB-010	PMA, PFB, PMD, PFD	0017-00101-2068	COVER/TRAY SCREW (20)

Handlebar Assemblies

Parts List

Item	Alpha Code	Part Number	Description (Quantity)
HB-011	PMA, PFB, PMD, PFD	9260400	LEFT DIPPED HANDLEBAR WELDMENT
HB-012	PMA, PFB, PMD, PFD	9281200	TOP HAND SENSOR (2)
HB-013	PMA, PFB, PMD, PFD	9281300	BOTTOM HAND SENSOR (2)
HB-014	PMA, PFB, PMD, PFD	REX2NAD	HAND SENSOR SCREWS (4)
HB-015	PMA, PFB, PMD, PFD	9584500	SPEED UP/DOWN BUTTON
HB-016	PMA, PFB, PMD, PFD	9276500	LEFT HANDLEBAR/UPRIGHT TUBING
HB-017	PMA, PFB, PMD, PFD	9273300	HANDLEBAR REAR BOLTS (4)
HB-018	PMA, PFB, PMD, PFD	0017-00101-2007	HANDLEBAR FRONT BOLTS (8)
HB-019	PMA, PFB, PMD, PFD	9259400	RIGHT DIPPED HANDLEBAR WELDMENT
HB-020	PMA, PFB, PMD, PFD	9259700	RIGHT HANDLEBAR/UPRIGHT TUBING
HB-021	PMA, PFB, PMD, PFD	9584100	START/STOP BUTTON
HB-022	PFB, PFD	9266518	LEFT HANDLEBAR SUPPORT (PLANET FITNESS)
	PMA, PMD	9266521	LEFT HANDLEBAR SUPPORT (PEARL WHITE)
	PMA, PMD	9266522	LEFT HANDLEBAR SUPPORT (TITANIUM)
	PMA, PMD	9266523	LEFT HANDLEBAR SUPPORT (METALLIC BLACK)
	PMA, PMD	9266527	LEFT HANDLEBAR SUPPORT (ARCTIC SILVER)
HB-023	PFB, PFD	9256718	RIGHT HANDLEBAR SUPPORT (PLANET FITNESS)
	PMA, PMD	9256721	RIGHT HANDLEBAR SUPPORT (PEARL WHITE)
	PMA, PMD	9256722	RIGHT HANDLEBAR SUPPORT (TITANIUM)
	PMA, PMD	9256723	RIGHT HANDLEBAR SUPPORT (METALLIC BLACK)
	PMA, PMD	9256727	RIGHT HANDLEBAR SUPPORT (ARCTIC SLIVER)
HB-024	PMA, PFB, PMD, PFD	REX2DVG	HANDLEBAR SUPPORT BOLTS (4)
HB-025	PMA, PFB, PMD, PFD	0017-00042-1055	GROMMET (2)
HB-026	PMA, PFB, PMD, PFD	9265200	LEFT REAR HANDLEBAR CABLE ASSY
HB-027	PMA, PFB, PMD, PFD	9265300	RIGHT REAR HANDLEBAR CABLE ASSY
HB-028	PMA, PFB, PMD, PFD	9275400	LEFT TOP ERGO GRIP
HB-029	PMA, PFB, PMD, PFD	9584000	LEFT ERGOBAR MEMBRANE KEYPAD
HB-030	PMA, PFB, PMD, PFD	9260300	LEFT BOTTOM ERGO GRIP
HB-031	PMA, PFB, PMD, PFD	9275300	RIGHT TOP ERGO GRIP
HB-032	PMA, PFB, PMD, PFD	9583900	RIGHT ERGOBAR MEMBRANE KEYPAD
HB-033	PMA, PFB, PMD, PFD	9259300	RIGHT BOTTOM ERGO GRIP
HB-034	PMA, PFB, PMD, PFD	0017-00101-2068	M4 X 0.7-6 G6G X 12 DIN PHL PAN SCREW (4)

ILLUSTRATION ON FOLLOWING PAGE

Handlebar Assemblies

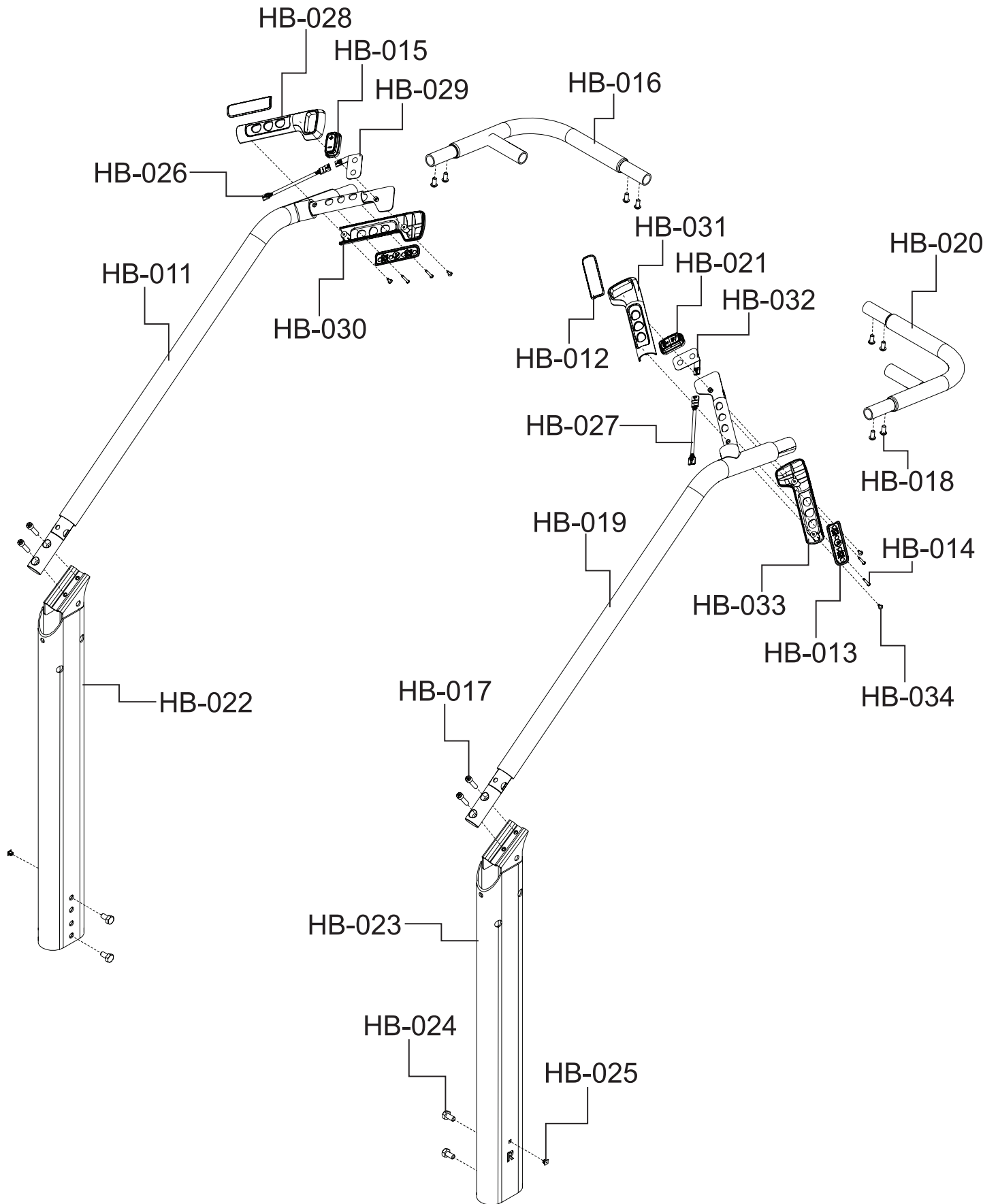

Console Supports

For 95PS do the weldments change? if yes need the part numbers

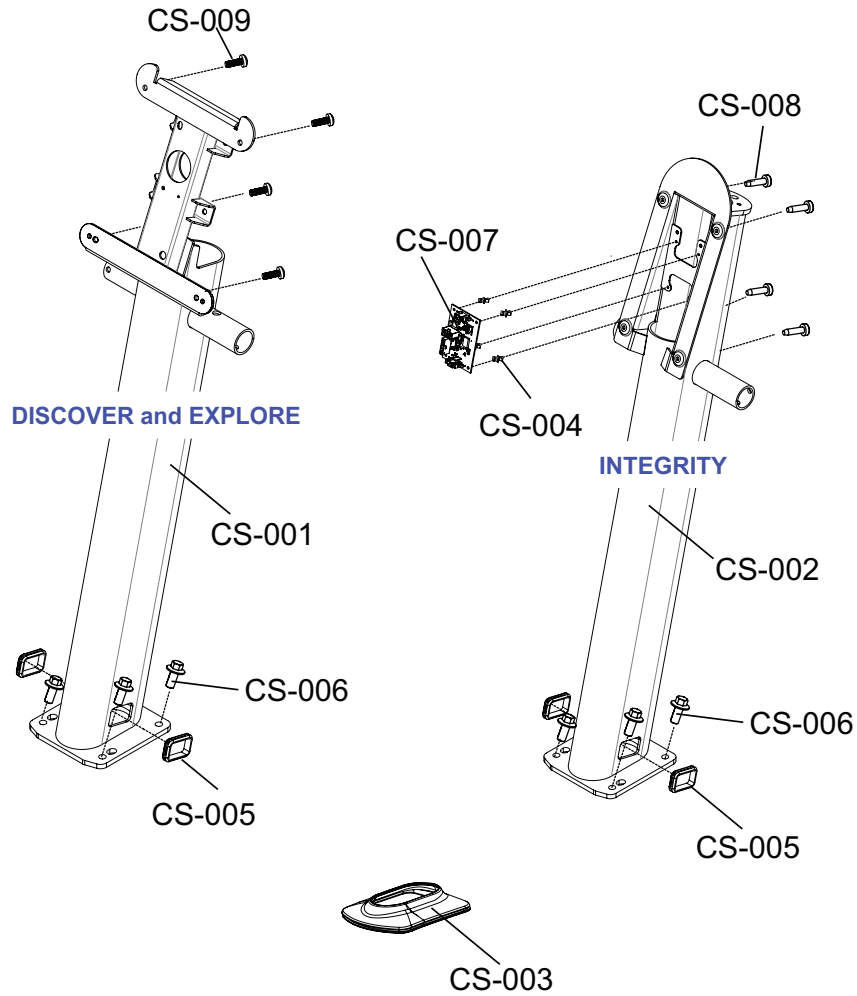

Parts List

Item	Alpha Code	Part Number	Description (Quantity)
CS-001	PMA, PMD	9278821	DISCOVER / EXPLORE CONSOLE UPRIGHT (PEARL WHITE)
	PMA, PMD	9278822	DISCOVER / EXPLORECONSOLE UPRIGHT (TITANIUM)
	PMA, PMD	9278823	DISCOVER / EXPLORE CONSOLE UPRIGHT (METALLIC BLACK)
	PMA, PMD	9278827	DISCOVER / EXPLORECONSOLE UPRIGHT (ARCTIC SILVER)
CS-002	PFB, PFD	9267018	INTEGRITY CONSOLE UPRIGHT (PLANET FITNESS)
	PMA, PMD	9267027	INTEGRITY CONSOLE UPRIGHT (ARCTIC SILVER)
CS-003	PMA, PFB, PMD, PFD	9268500	CONSOLE SUPPORT GASKET
CS-004	PMA, PFB, PMD, PFD	9261200	STANDOFF (4)
CS-005	PMA, PFB, PMD, PFD	REX2NEK	GROMMET (2)
CS-006	PMA, PFB, PMD, PFD	0017-00101-2091	CONSOLE SUPPORT BOLT (4)
CS-007	PMA, PFB, PMD, PFD	A084-92400-0000	ACTIVITY ZONE BOARD
CS-008	PMA, PFB, PMD, PFD	0017-00101-1744	INTEGRITY CONSOLE MOUNTING SCREW (4)
CS-009	PMA, PMD	0017-00101-1940	DISCOVER CONSOLE MOUNTING SCREW (4)

Drive System

Parts List

Item	Alpha Code	Part Number	Description (Quantity)
DS-001	PMA, PFB, PMD, PFD	9255000	LOWER AXLE ASSEMBLY
DS-002	PMA, PFB, PMD, PFD	9248400	UPPER AXLE ASSEMBLY
DS-003	PMA, PFB, PMD, PFD	9248500	LARGE SPROCKET
DS-004 *	PMA, PFB, PMD, PFD	9258500	MAIN CHAIN (2)
DS-005	PMA, PFB, PMD, PFD	9251300	DRIVE CHAIN
DS-006	PMA, PFB, PMD, PFD	9284600	CHAIN MASTER LINK (3)
DS-007	PMA, PFB, PMD, PFD	9258400	CHAIN BEARING (16)
DS-008	PMA, PFB, PMD, PFD	9254700	LOWER AXLE PILLOW BLOCK (2)
DS-009	PMA, PFB, PMD, PFD	9273000	LOWER PILLOW BLOCK MOUNTING BOLT (4)
DS-010	PMA, PFB, PMD, PFD	9271800	WASHER (4)
DS-011	PMA, PFB, PMD, PFD	9282100	UPPER PILLOW BLOCK (2)
DS-012	PMA, PFB, PMD, PFD	9273000	UPPER PILLOW BLOCK MOUNTING BOLT (4)
DS-013	PMA, PFB, PMD, PFD	9271800	WASHER (4)
DS-014	PMA, PFB, PMD, PFD	9272900	CHAIN TENSIONING BOLT (2)
DS-015	PMA, PFB, PMD, PFD	0017-00103-0328	NUT (4)
DS-016	PMA, PFB, PMD, PFD	9286500	AXLE SCREW
DS-017	PMA, PFB, PMD, PFD	9282600	AXLE WASHER
DS-018	PMA, PFB, PMD, PFD	9282700	SET SCREW (2)
DS-019	PMA, PFB, PMD, PFD	9282200	AXLE KEY

ILLUSTRATION ON FOLLOWING PAGE

** When replacing the MAIN CHAIN it may be necessary to order replacement crimped retaining rings.*

Drive System

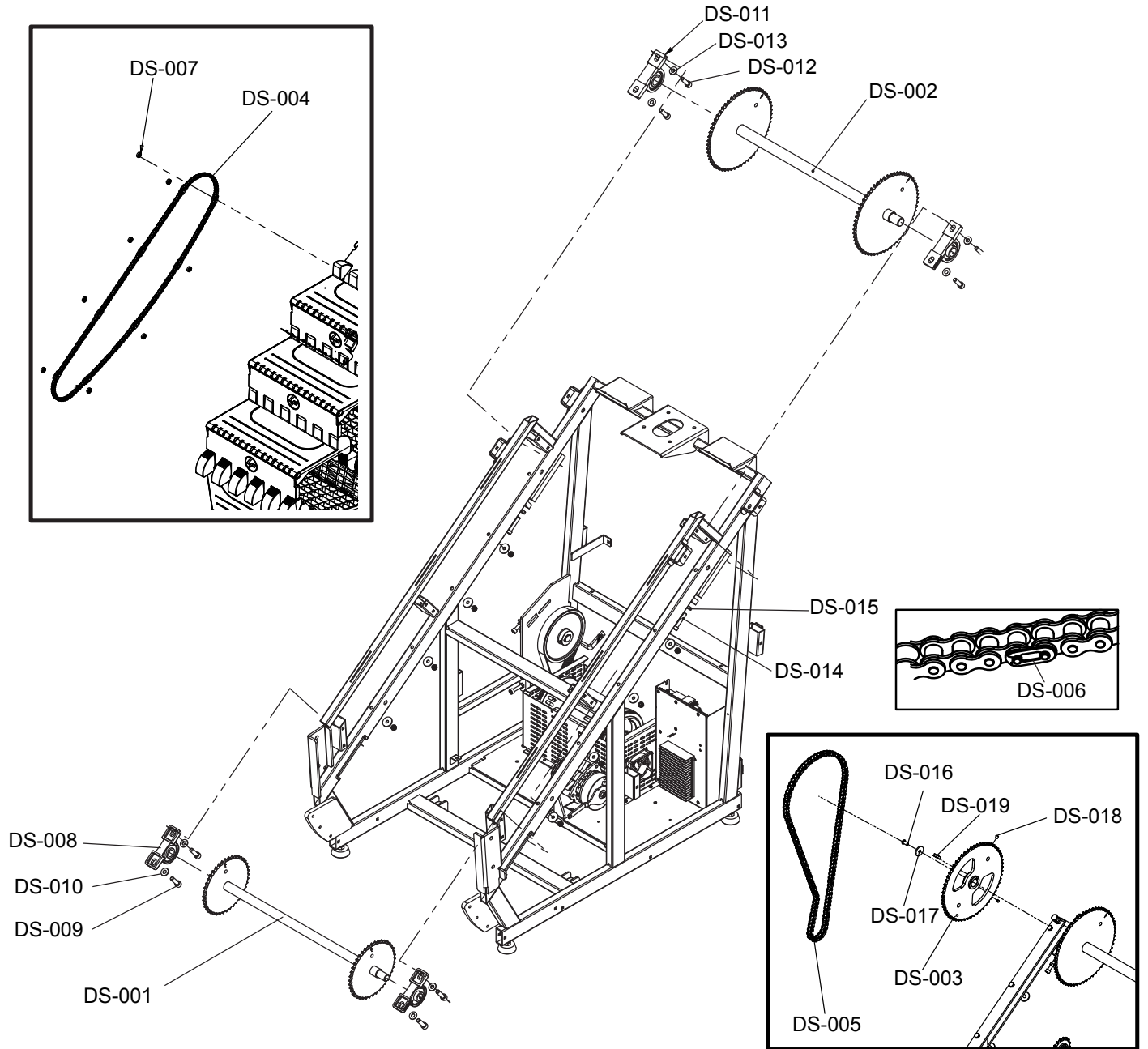

Drive System

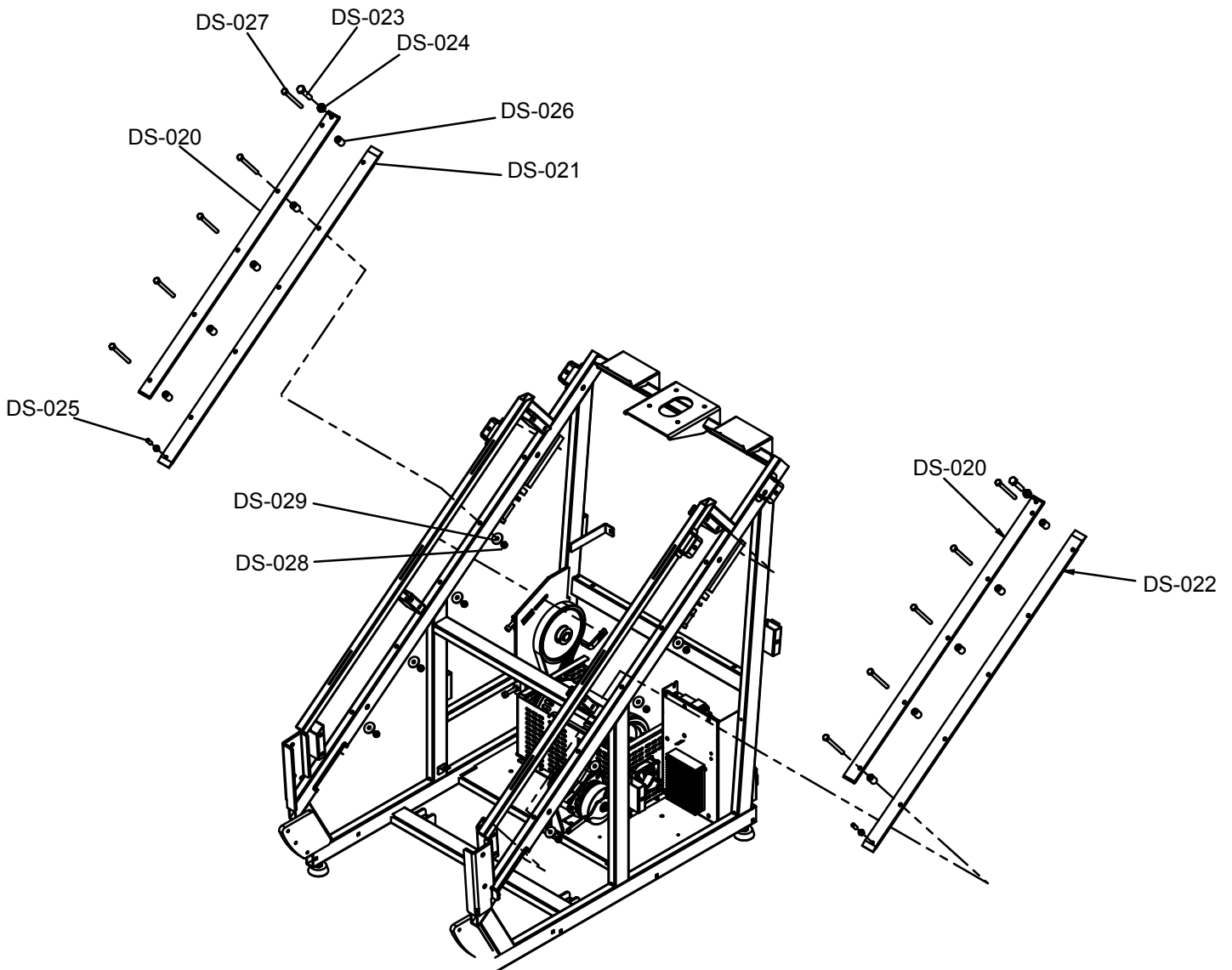

Parts List

Item	Alpha Code	Part Number	Description (Quantity)
DS-020	PMA, PFB, PMD, PFD	9255200	TOP WEAR BAR (2)
DS-021	PMA, PFB, PMD, PFD	9283600	LEFT BOTTOM WEAR BAR
DS-022	PMA, PFB, PMD, PFD	9255100	RIGHT BOTTOM WEAR BAR
DS-023	PMA, PFB, PMD, PFD	9285600	WEAR BAR BOLT (2)
DS-024	PMA, PFB, PMD, PFD	0017-00103-0384	WEAR BAR NUT (2)
DS-025	PMA, PFB, PMD, PFD	9273200	SET SCREW (2)
DS-026	PMA, PFB, PMD, PFD	9255300	SPACER (10)
DS-027	PMA, PFB, PMD, PFD	9272700	BOLT (10)
DS-028	PMA, PFB, PMD, PFD	9274500	NUT (8)
DS-029	PMA, PFB, PMD, PFD	9271700	WASHER (8)

Drive System

Parts List

Item	Alpha Code	Part Number	Description (Quantity)
DS-030	PMA, PFB, PMD, PFD	9267300	BEARING HUB ASSEMBLY
DS-031	PMA, PFB, PMD, PFD	9269600	HUB ASSEMBLY MOUNTING BOLT (3)
DS-032	PMA, PFB, PMD, PFD	9276300	HUB ASSEMBLY SPROCKET
DS-033	PMA, PFB, PMD, PFD	9282700	SET SCREW (2)
DS-034	PMA, PFB, PMD, PFD	0017-00100-0242	RETAINING RING (2)
DS-035	PMA, PFB, PMD, PFD	9272400	KEY (2)
DS-036	PMA, PFB, PMD, PFD	9273800	SPROCKET IDLER
DS-037	PMA, PFB, PMD, PFD	9274300	SPROCKET IDLER BEARING
DS-038	PMA, PFB, PMD, PFD	9274400	SPROCKET TENSIONER SPACER
DS-039	PMA, PFB, PMD, PFD	9271600	WASHER
DS-040	PMA, PFB, PMD, PFD	9282900	BOLT
DS-041	PMA, PFB, PMD, PFD	9274200	RETAINING RING
DS-042	PMA, PFB, PMD, PFD	9285500	SPROCKET/IDLER TENSIONING BOLT (2)
DS-043	PMA, PFB, PMD, PFD	0017-00103-0328	NUT (2)
DS-044	PMA, PFB, PMD, PFD	9274100	TENSIONER PUSH ARM
DS-045	PMA, PFB, PMD, PFD	9249800	PULLEY
DS-046	PMA, PFB, PMD, PFD	9282700	SET SCREW (2)
DS-047	PMA, PFB, PMD, PFD	9251400	DRIVE BELT
DS-048	PMA, PFB, PMD, PFD	9314600	IDLER PULLEY
DS-049	PMA, PFB, PMD, PFD	9279700	BOLT
DS-050	PMA, PFB, PMD, PFD	9279500	IDLER PUSH ARM

ILLUSTRATION ON FOLLOWING PAGE

Drive System

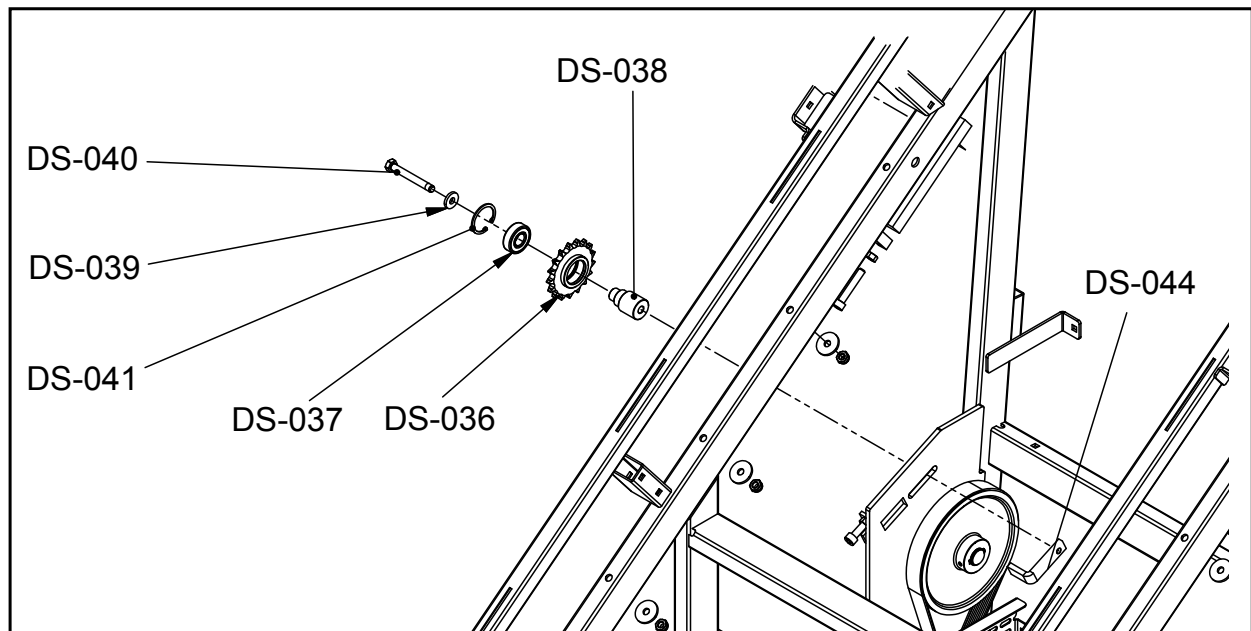
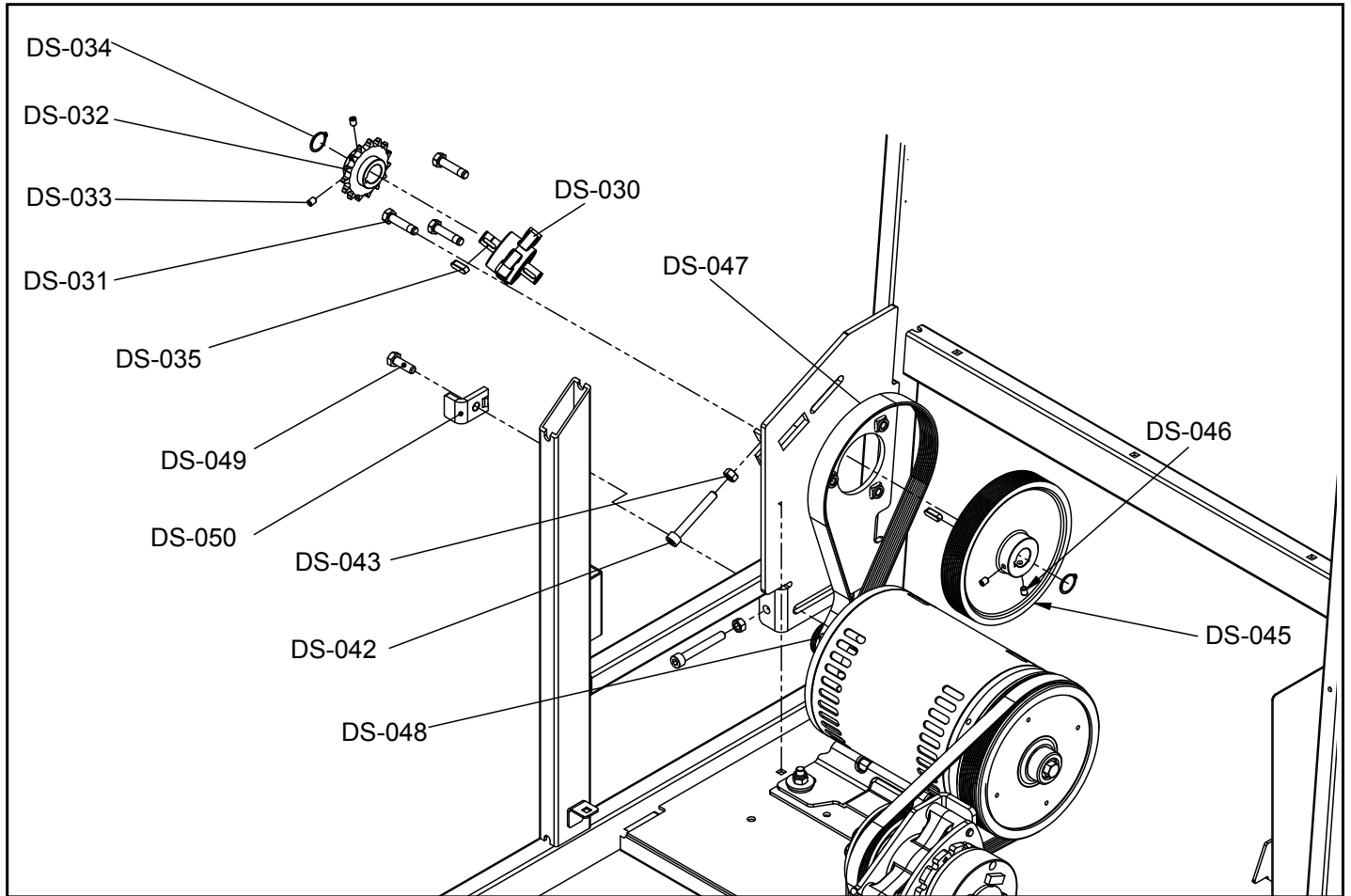

Base Electronics

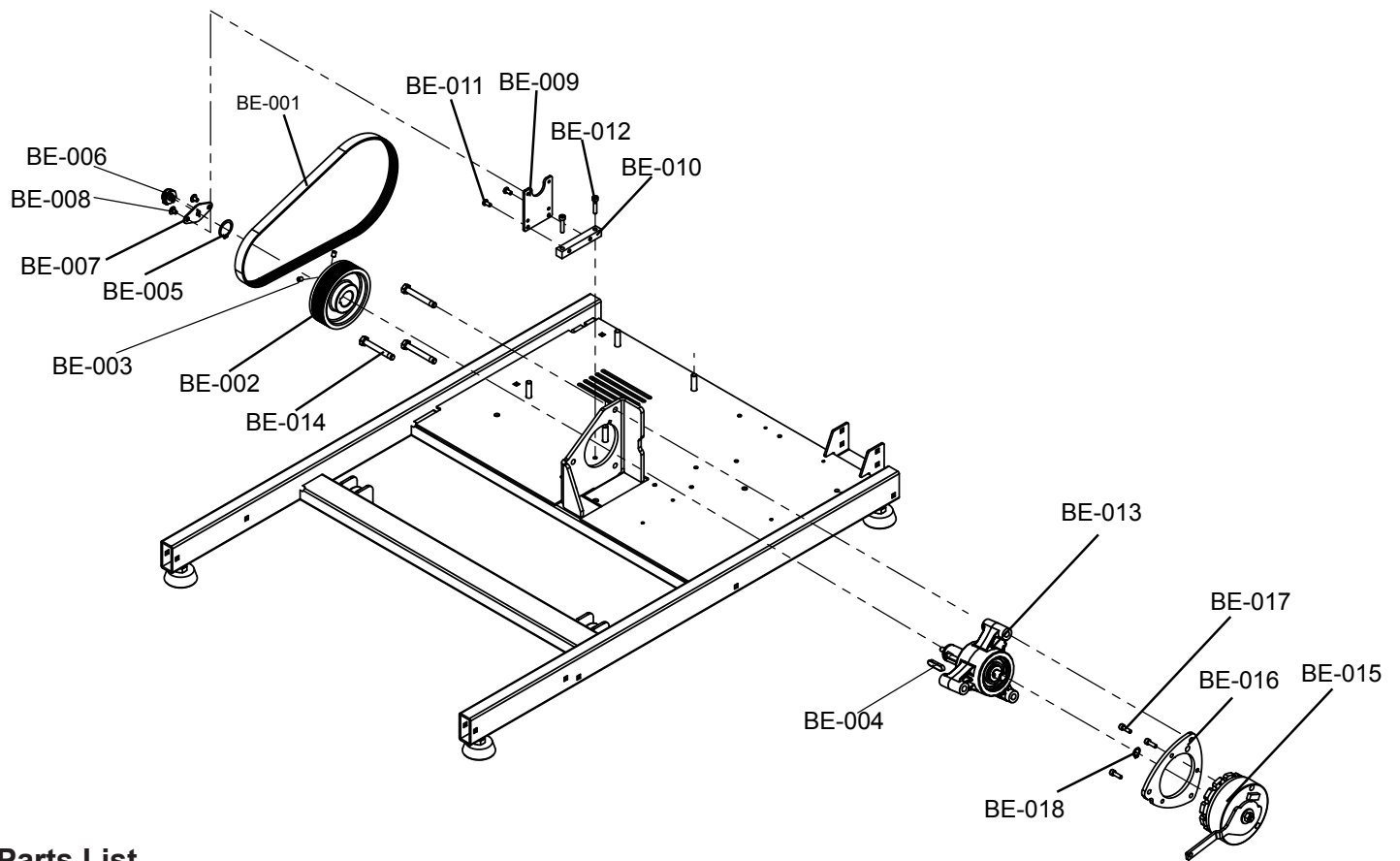

Parts List

Item	Alpha Code	Part Number	Description (Quantity)
BE-001	PMA, PFB, PMD, PFD	9248000	BRAKE BELT
BE-002	PMA, PFB, PMD, PFD	9262100	BRAKE PULLEY
BE-003	PMA, PFB, PMD, PFD	9282700	SET SCREW (2)
BE-004	PMA, PFB, PMD, PFD	9280000	KEY
BE-005	PMA, PFB, PMD, PFD	9274700	RETAINING RING
BE-006	PMA, PFB, PMD, PFD	9587500	ENCODER KIT
BE-007	PMA, PFB, PMD, PFD	9271300	ENCODER ALIGNMENT PLATE
BE-008	PMA, PFB, PMD, PFD	9272300	ENCODER ALIGNMENT PLATE SCREWS (2)
BE-009	PMA, PFB, PMD, PFD	9247900	ENCODER MOUNTING BRACKET
BE-010	PMA, PFB, PMD, PFD	9271900	MOUNTING BRACKET BASE
BE-011	PMA, PFB, PMD, PFD	9272200	MOUNTING BRACKET SCREWS (2)
BE-012	PMA, PFB, PMD, PFD	9272100	MOUNTING BASE SCREWS (2)
BE-013	PMA, PFB, PMD, PFD	9267200	BRAKE/DRIVE HUB ASSEMBLY
BE-014	PMA, PFB, PMD, PFD	9285400	BRAKE/DRIVE MOUNTING BOLTS (3)
BE-015	PMA, PFB, PMD, PFD	9246300	BRAKE
BE-016	PMA, PFB, PMD, PFD	9262700	BRAKE MOUNTING PLATE
BE-017	PMA, PFB, PMD, PFD	9272800	BRAKE MOUNTING BOLTS (3)
BE-018	PMA, PFB, PMD, PFD	9282000	RETAINING RING 12MM X 1MM

Base Electronics

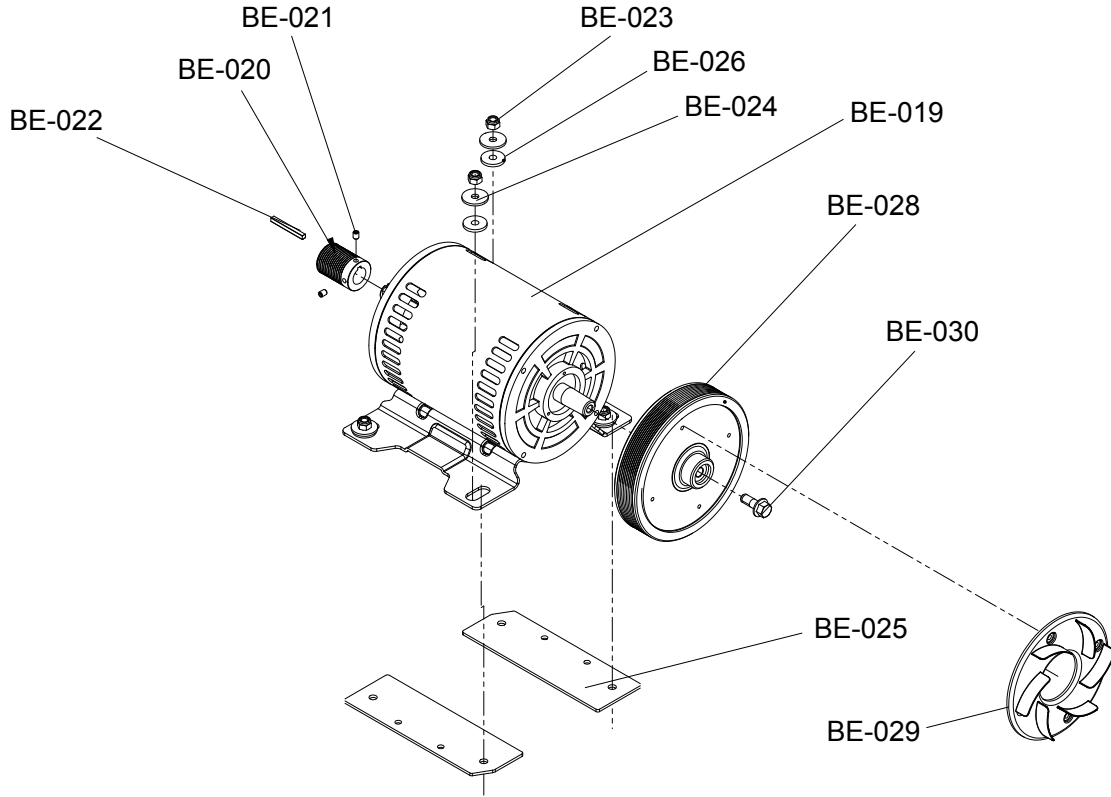

Parts List

Item	Alpha Code	Part Number	Description (Quantity)
BE-019	PMA, PFB, PMD, PFD	0K75-01001-0000	DRIVE MOTOR
BE-020	PMA, PFB, PMD, PFD	9282800	DRIVE MOTOR PULLEY
BE-021	PMA, PFB, PMD, PFD	9282700	SET SCREW (2)
BE-022	PMA, PFB, PMD, PFD	9280100	KEY
BE-023	PMA, PFB, PMD, PFD	9282400	NUT (4)
BE-024	PMA, PFB, PMD, PFD	9271700	WASHER (4)
BE-025	PMA, PFB, PMD, PFD	0K58-01256-0001	ISOLATING PAD (2)
BE-026	PMA, PFB, PMD, PFD	0K58-01255-0000	ISOLATING SHOULDER WASHER (4)
BE-027	PMA, PFB, PMD, PFD	0017-00003-1089	LINE FILTER ILLUSTRATED ON NEXT page
BE-028	PMA, PFB, PMD, PFD	9246100	FLY WHEEL
BE-029	PMA, PFB, PMD, PFD	9275000	FLY WHEEL FAN
BE-030	PMA, PFB, PMD, PFD	0017-00101-1885	FLYWHEEL BOLT

Base Electronics

*** Note:** For Models 95PS-ALLXX-XX01 and 95PS-ALLXX-XX01PF (serial numbers PMA106590, PFB101456, or prior): Replacement of items BE33, BE61, BE65 or BE66 require the replacement of ALL FOUR shields (also requires (4) BE67 to mount).

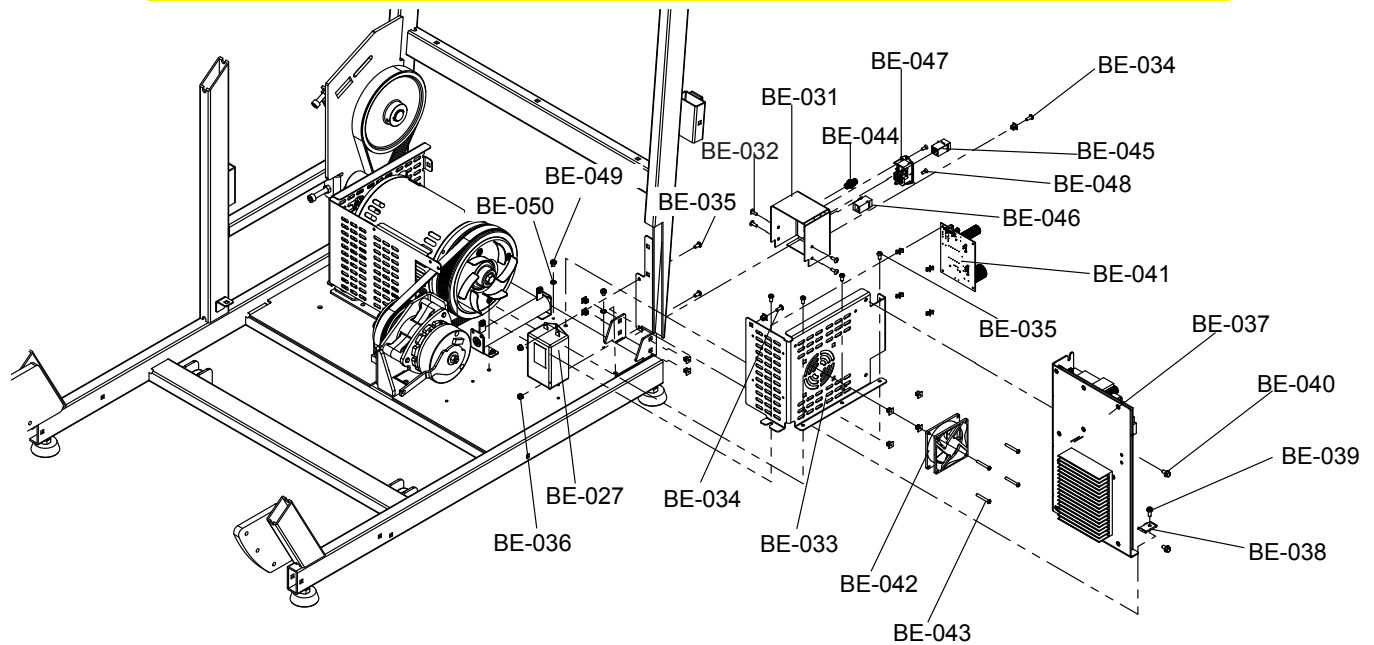

Parts List

Item	Alpha Code	Part Number	Description (Quantity)
BE-031	PMA, PFB, PMD, PFD	9250800	IEC CONNECTOR BOX
BE-032*	PMA, PFB, PMD, PFD	0017-00101-2068	IEC CONNECTOR SCREWS (4)
BE-033	PMA, PFB, PMD, PFD	1002906-0001	INSIDE ELECTRICAL BOX
BE-034	PMA, PFB, PMD, PFD	0017-00101-2068	SCREW (14)
BE-035	PMA, PFB, PMD, PFD	9272200	SCREW (11)
BE-036	PMA, PFB, PMD, PFD	0017-00103-0350	NUT (2)
BE-037	PMA, PFB, PMD, PFD	AK98-00001-0000	MOTOR CONTROLLER
BE-038	PMA, PFB, PMD, PFD	9314200	MOTOR CONTROLLER TAB
BE-039	PMA, PFB, PMD, PFD	9285300	SCREW
BE-040	PMA, PFB, PMD, PFD	0017-00101-2070	HEX BOLT (2)
BE-041	PMA, PFB, PMD, PFD	B084-92402-0000	FAN BRAKE BOARD
BE-042	PMA, PFB, PMD, PFD	9264300	FAN
BE-043	PMA, PFB, PMD, PFD	9278700	MOUNTING SCREWS (4)
BE-044	PMA, PFB, PMD, PFD	0017-00021-2846	COAX CONNECTOR
BE-045	PMA, PFB, PMD, PFD	0017-00021-3195	SHIELDED CAT5E COUPLER
BE-046	PMA, PFB, PMD, PFD	0017-00021-2847	CAT5E COUPLER
BE-047	PMA, PFB, PMD, PFD	9250700	POWER CONNECTOR
BE-048	PMA, PFB, PMD, PFD	9273400	SCREW (2)
BE-049	PMA, PFB, PMD, PFD	9285200	GROUND SCREW (2)
BE-050	PMA, PFB, PMD, PFD	9273600	STAR WASHER (2)

Base Electronics

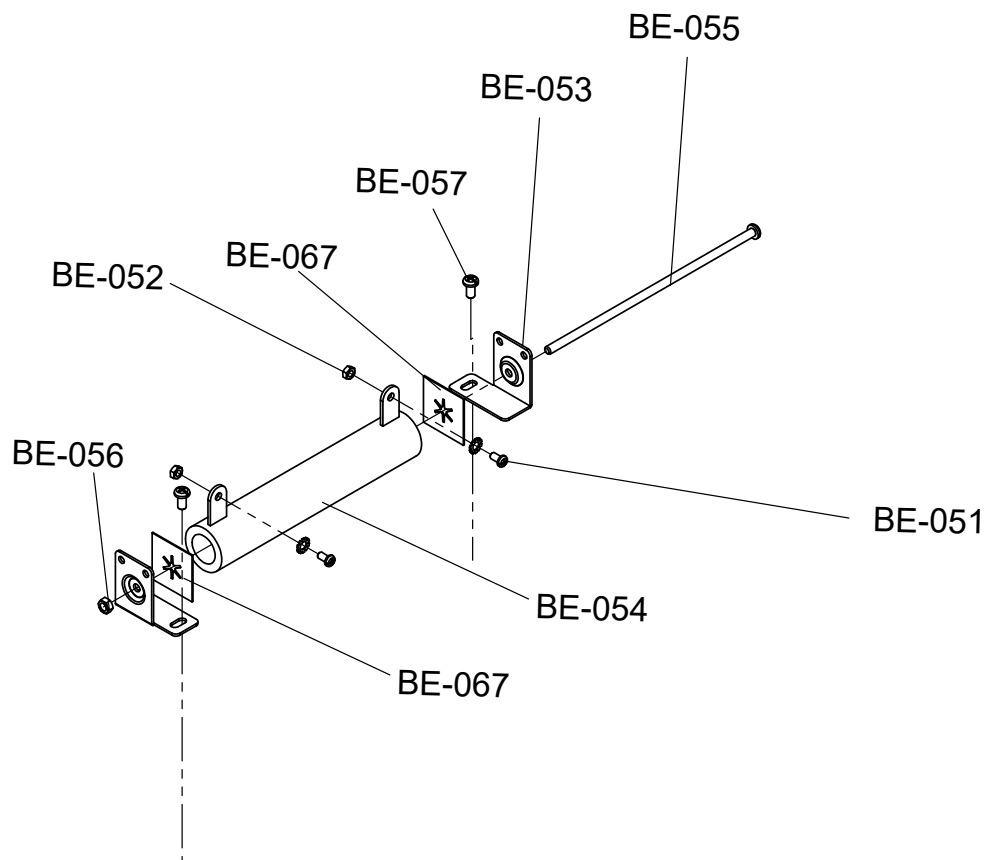

Parts List

Item	Alpha Code	Part Number	Description (Quantity)
BE-051	PMA, PFB, PMD, PFD	0017-00101-2095	TOP RESISTOR ASSEMBLY MOUNTING SCREW (2)
BE-052	PMA, PFB, PMD, PFD	0017-00103-0388	RESISTOR ASSEMBLY NUT (2)
BE-053	PMA, PFB, PMD, PFD	9273500	BRKT; RESISTOR MTG (2)
BE-054	PMA, PFB, PMD, PFD	100E-00002-0099	WIRE-WOUND RESISTOR
BE-055	PMA, PFB, PMD, PFD	0017-00101-2072	RESISTOR BOLT
BE-056	PMA, PFB, PMD, PFD	0017-00103-0385	RESISTOR NUT
BE-057	PMA, PFB, PMD, PFD	9272200	BOTTOM RESISTOR ASSEMBLY MOUNTING SCREW (2)
BE-067	PMA, PMD	9286700	INSULATOR, FISHPAPER 0.030" THICK (2)

Base Electronics

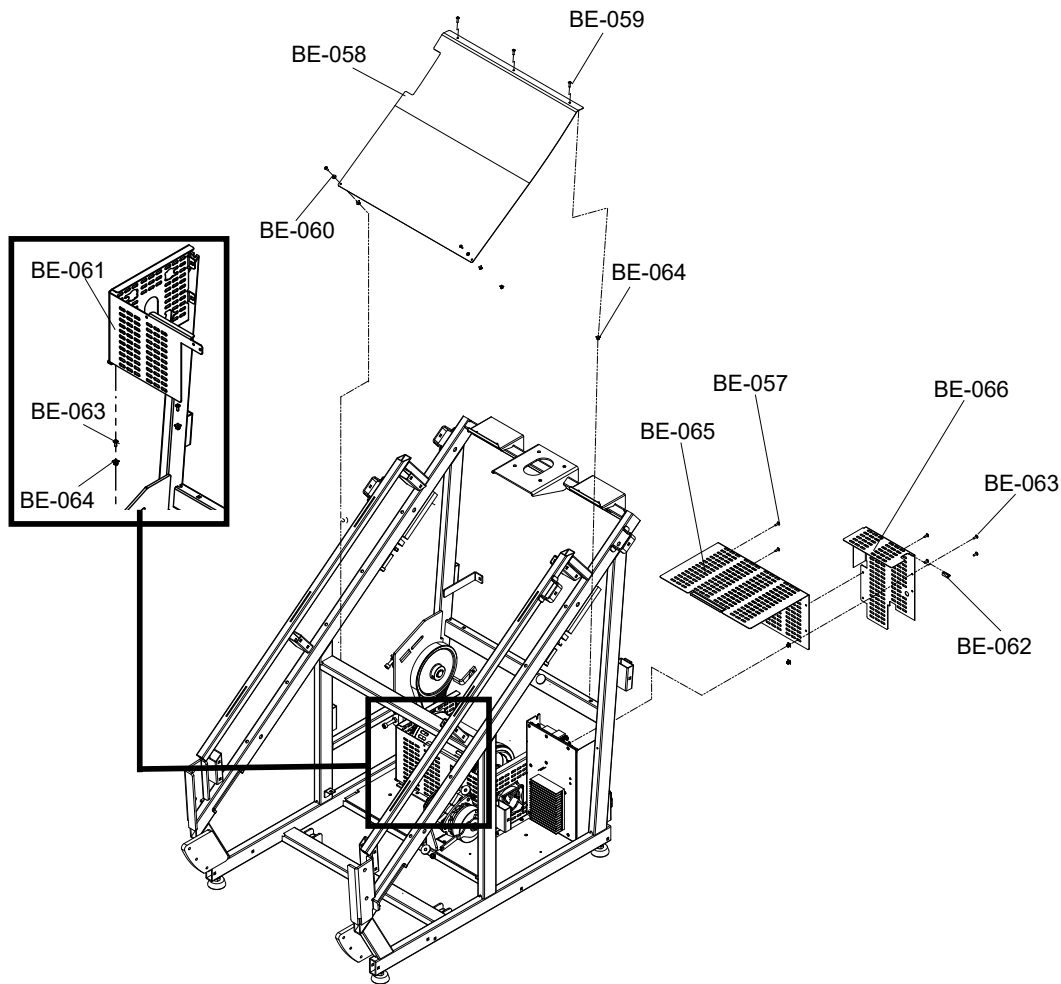

Parts List

Item	Alpha Code	Part Number	Description (Quantity)
BE-057	PMA, PFB, PMD, PFD	9272200	M5 X 10 PHILLIPS PAN HEAD SCREW (4)
BE-058	PMA, PFB, PMD, PFD	9274800	ELECTRONICS SWEAT SHIELD
BE-059	PMA, PFB, PMD, PFD	9276700	ELECTRONICS SWEAT SHIELD SCREW (5)
BE-060	PMA, PFB, PMD, PFD	9284400	ELECTRONICS SWEAT SHIELD WASHER (2)
BE-061*	PMA, PFB, PMD, PFD	1002910-0001	MOTOR CONTROLLER BOX
BE-062	PMA, PFB, PMD, PFD	9284300	GROMMET: EDGE 20MM WIDE (2)
BE-063	PMA, PFB, PMD, PFD	0017-00101-2068	SCREW (2)
BE-064	PMA, PFB, PMD, PFD	0017-00042-1055	GROMMET: PLASTIC (14)
BE-065*	PMA, PFB, PMD, PFD	1002907-0001	ELECTRICAL BOX TOP
BE-066*	PMA, PFB, PMD, PFD	1002904-0001	REAR ELECTRICAL MOTOR BOX

*** Note:** For Models 95PS-ALLXX-XX01 and 95PS-ALLXX-XX01PF (serial numbers PMA106590, PFB101456, or prior): Replacement of items BE33, BE61, BE65 or BE66 require the replacement of ALL FOUR shields (also requires (4) BE57 to mount).

Wiring Diagram Parts List

Parts List

Item	Alpha Code	Part Number	Description (Quantity)
WD-001	PFB, PFD	9265800	C-SAFE CABLE EXTENSION
WD-002	PMA, PFB, PMD, PFD	9264700	C-SAFE CABLE
WD-003	PMA, PFB, PMD, PFD	9264600	ETHERNET CABLE
WD-004	PMA, PFB, PMD, PFD	9264800	COAX CABLE
WD-005	PMD, PFD	1003262-0001	CONSOLE CABLE
WD-006	PMD, PFD	1003267-0001	MIB POWER
WD-007	PMA, PFB, PMD, PFD	9263800	RESISTOR CABLE
WD-008	PMD, PFD	1003268-0001	CBL ASSY: AC, FILTER TO CONTROLLER
WD-009	PMA, PFB, PMD, PFD	9263300	CBL ASSY: AC, SWITCH TO FILTER
WD-010	PMA, PFB, PMD, PFD	9263200	CBL ASSY: AC, IEC TO SWITCH
WD-011	PMA, PFB, PMD, PFD	9263500	CBL ASSY: MOV; FILTER
WD-012	-	9263600	CBL ASSY: HI-POT JUMPER
WD-013	PMA, PFB, PMD, PFD	9263100	CBL ASSY: GROUND
WD-014	PMA, PFB, PMD, PFD	9263900	CBL ASSY: EXTENSION, DRIVE MOTOR
WD-015	PMA, PFB, PMD, PFD	9264000	CBL ASSY: EXTENSION, THERMAL SWITCH
WD-016	PMA, PFB, PMD, PFD	9264100	CBL ASSY: ENCODER
WD-017	PMA, PFB, PMD, PFD	9264200	CBL ASSY: PCB; BRAKE/FAN CONTROL
WD-018	PFB, PFD	9265600	CBL ASSY: LIFE PULSE, EXTENSION
WD-019	PMA, PFB, PMD, PFD	9265500	CBL ASSY: LIFE PULSE, HANDLES (2)
WD-020	PFB, PFD	9265100	CBL ASSY: INTERFACE TO CONSOLE, 92367
WD-021	PMA, PFB, PMD, PFD	9265200	CBL ASSY: SWITCH_A
WD-022	PMA, PFB, PMD, PFD	9265300	CBL ASSY: SWITCH_B
WD-023	PMA, PFB, PMD, PFD	9265400	CBL ASSY: CONTROLLER TO INTERFACE PCB
WD-024	PMA, PFB, PMD, PFD	9266100	KEYPAD; MEMBRANE ERGOBAR RT
WD-025	PMA, PFB, PMD, PFD	9266200	KEYPAD; MEMBRANE ERGOBAR LT
WD-026	PMA, PFB, PMD, PFD	AK65-00103-0003	CBL ASSY: GROUND ESD
WD-027	PMA, PMD, PMD, PFD	9265700	CBL ASSY: COMMUNICATION, DISCOVER
WD-028	PMA, PFD	121E-00001-0010	FERRITE

WIRING DIAGRAMS ON FOLLOWING PAGES

Wiring Diagram - Console - Integrity

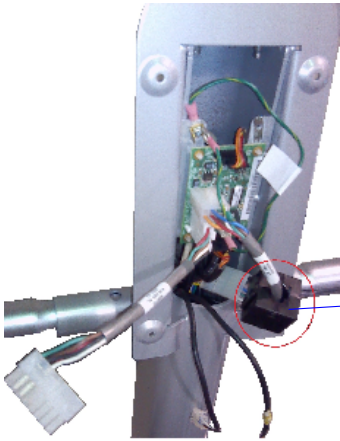

FERRITE "A"

C-SAFE PINOUT (P9/P10)	
PIN#	SIGNAL DESCRIPTION
1	MYE_LEFT
2	MYE_RIGHT
3	RECEIVE DATA (RxD)
4	TRANSMIT DATA (TxD)
5	VCARDIO
6	N/C
7	GROUND
8	N/C

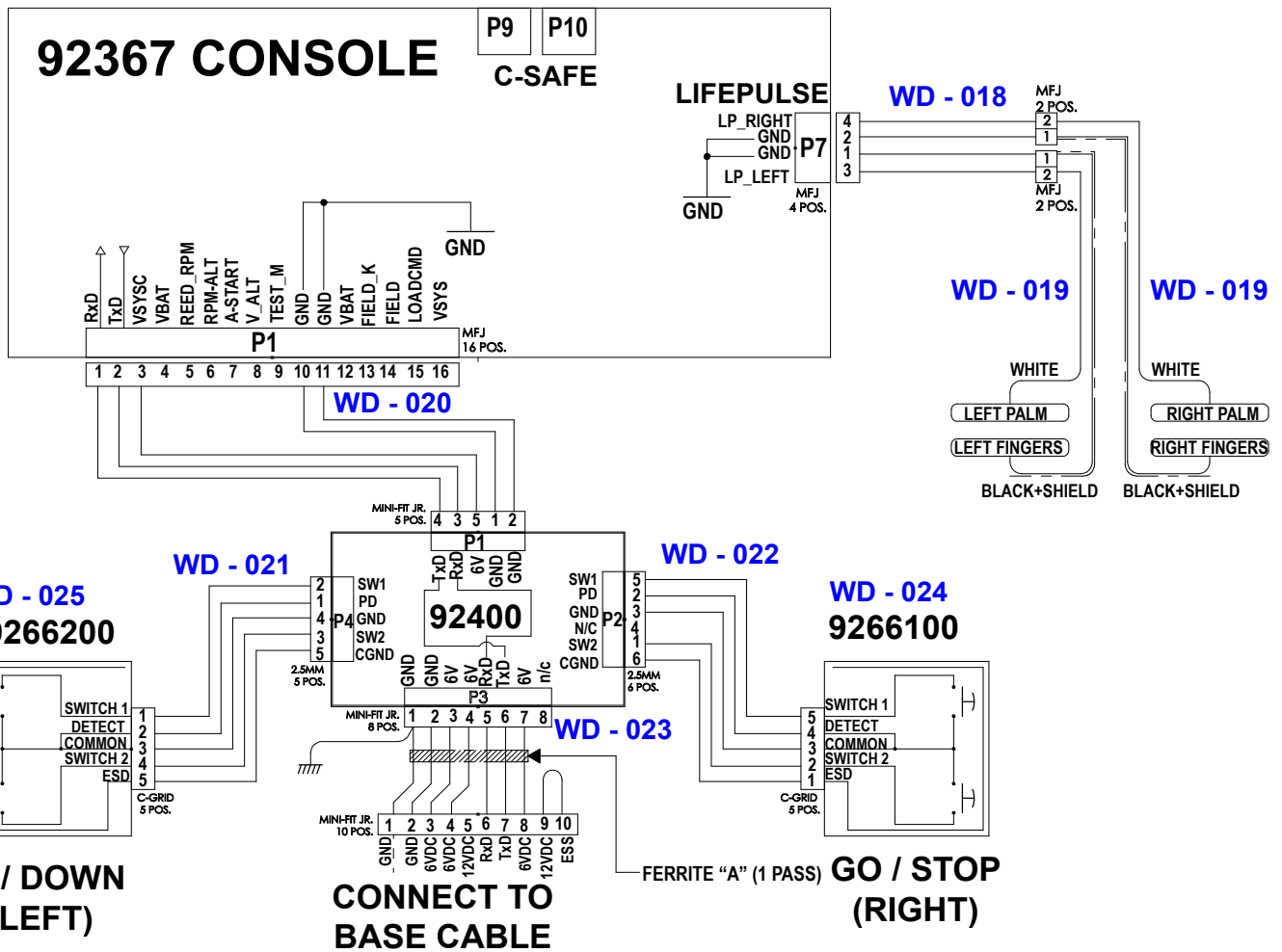

Wiring Diagram - Console - Discover

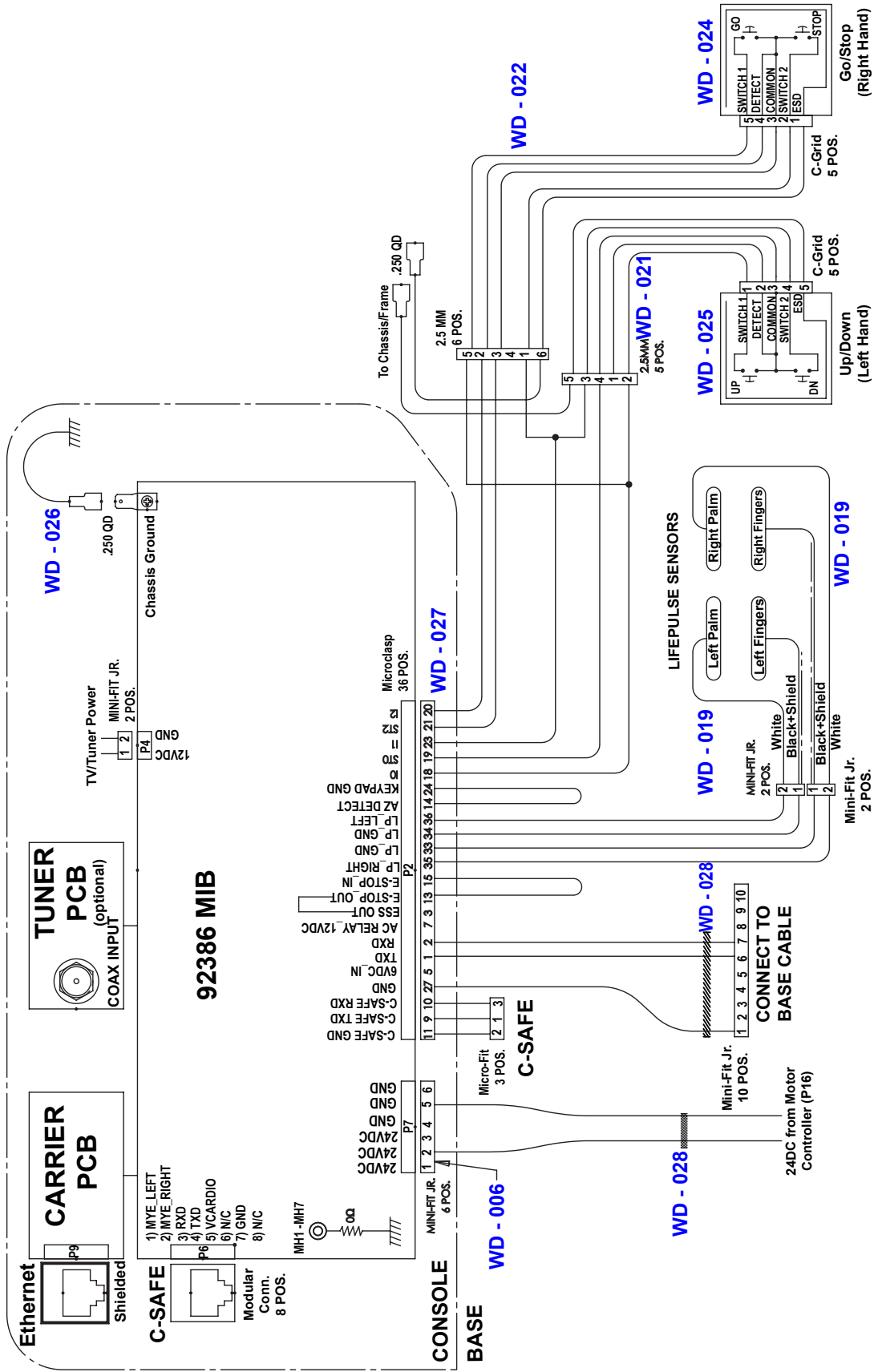

Wiring Diagram - Console - Explore

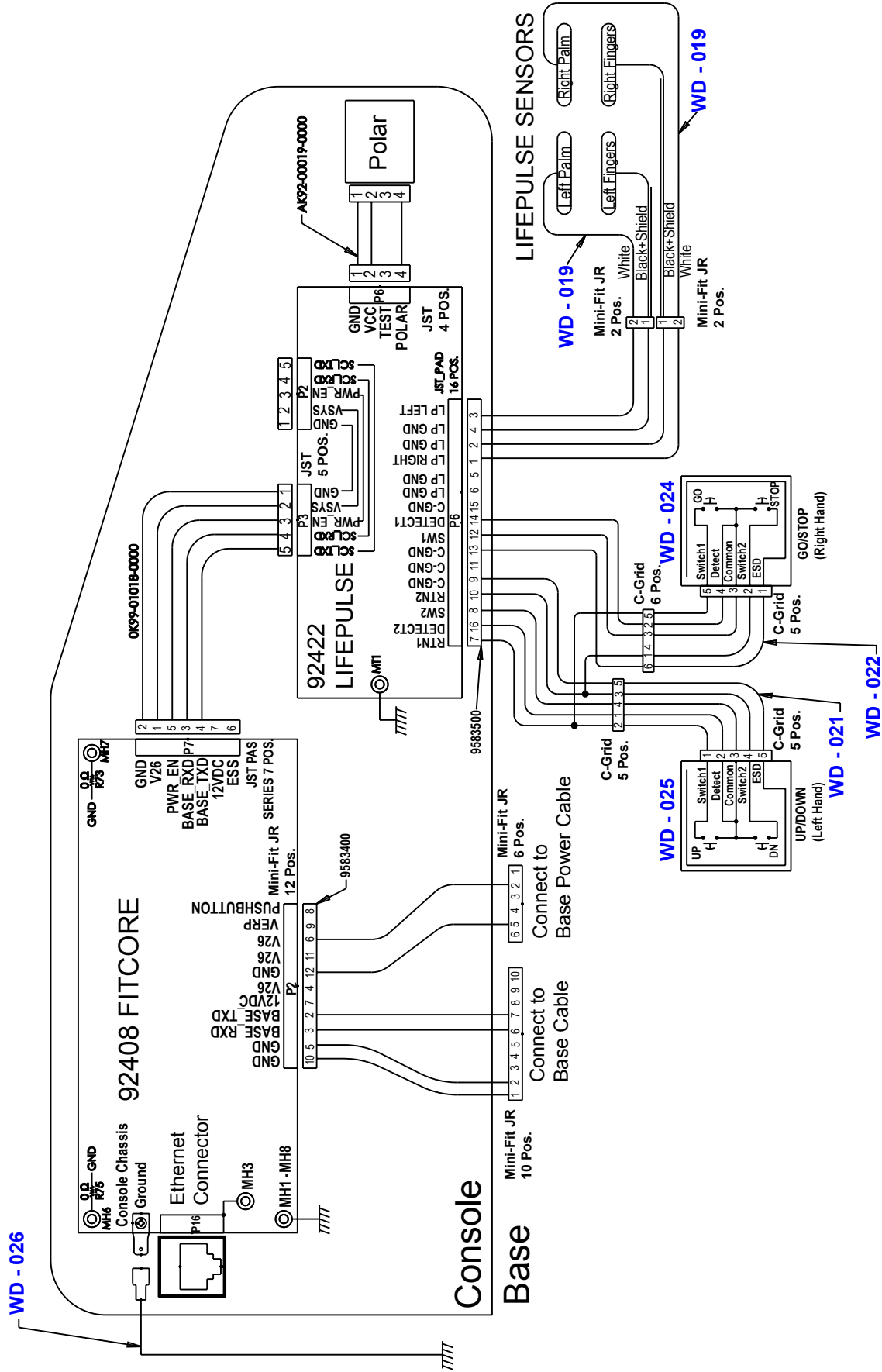

Consoles - Discover SE, Discover SI & EXPLORE



Discover SE Console - 16 inch

Use the console serial number to select the correct console.
Please refer to the Discover SE parts manual 16DN-XXXXXX-XX.



Discover SI Console - 10 inch

Use the console serial number to select the correct console.
Please refer to the Discover SI parts manual 10DN-XXXXXX-XX.



Explore Console

Use the console serial number to select the correct console.
Please refer to the Explore parts manual EXPTS-XXXXXX-XX, EXPNTS-XXXXXX-XX.

Console Assembly - Integrity

Parts List

Item	Alpha Code	Part Number	Description (Quantity)
CN-001	PMA, PMD	PLED-ENGXX-02	INTEGRITY POWERMILL EXERCISE EQUIP CONSOLE
	PFB, PFD	PLED-ENGXX-02PF	POWERMILL INTEGRITY PLANET FITNESS CONSOLE
CN-002	PMA, PFB, PMD, PFD	A084-92367-0003	PROGRAMMED PCB: B084-92367-0000 FOR POWERMILL
CN-003	PMA, PFB, PMD, PFD	0017-00101-1650	VMI 6-19X 6 PHL PAN PLT ST BZ B
CN-004	PMA, PFB, PMD, PFD	AK69-00157-0000	CBL-ASSY: POLAR PCB W/HEADER
CN-005	PMA, PMD	AK98-00005-0000	OVERLAY:BEZEL;SWITCH ASSY:IPOD HOLDER;PMIL;ENG
	PFB, PFD	AK98-00006-0000	OVERLAY:BEZEL;SWITCH ASSY:IPODHOLDER;PMILL;PF;ENG
CN-006	PMA, PFB, PMD, PFD	0K86-01004-0200	PANEL ACCESS: IPOD CABLE
CN-007	PMA, PFB, PMD, PFD	0K86-01003-0200	HOLDER: IPOD
CN-008	PMA, PFB, PMD, PFD	AK86-00003-0000	CBL ASSY: CONSOLE, I-POD; NON-TREAD
CN-009	PMA, PFB, PMD, PFD	0017-00101-1811	6-32X10 PHL PAN MS ST BZ B (2)
CN-010	PMA, PFB, PMD, PFD	3223501	6-20 X 8 PHL PAN B ST ZN (4)
CN-011	PMA, PFB, PMD, PFD	AK86-00025-0201	ASSY: HEADPHONE JACK PANEL; SHADOW GREY
CN-012	PMA, PFB, PMD, PFD	0017-00101-1811	6-32X10 PHL PAN MS ST BZ B (1)
CN-013	PMA, PFB, PMD, PFD	0K39-01044-0001	TAPE: ADHESIVE; DBL-SIDED B
CN-014	PMA, PFB, PMD, PFD	AK86-00087-0200	OVERMOLDED IPOD CABLE; NON TREAD; INTEGRITY
CN-015	PMA, PFB, PMD, PFD	118E-00001-0244	HEART RATE RECEIVER: CODED; RE07L
CN-016	PMA, PFB, PMD, PFD	B084-92368-0000	CLASSIC LOWER CONSOLE
CN-017	PMA, PFB, PMD, PFD	0017-00101-1650	VMI 6-19X 6 PHL PAN PLT ST BZ B (5)
CN-018	PMA, PFB, PMD, PFD	0017-00101-1242	VMI 8-18X12 PHL PAN AB ST BZ B (6)
CN-019	PMA, PFB, PMD, PFD	0K62-01026-0202	DOOR: BATTERY; SHDW-02XX
CN-020	PMA, PFB, PMD, PFD	AK86-00024-0201	CONSOLE CASE ASSY: NON-TREAD; SHADOW GREY
CN-021	PMA, PFB, PMD, PFD	0K62-01175-0001	DECAL: INTEGRITY CONSOLE REAR (Not Shown)

ILLUSTRATION ON FOLLOWING PAGE

Console Assembly - Integrity

CN-001 - Console Case Assembly

